

iQ parts
IQ-PARTS-SHOP.COM



**SPECS &
INFORMATION**



W2

SUPRA W2 Hose Clamp AISI 430 Stainless Steel

Due to its revolutionary swivelling bridge, Supra W2 can be mounted in the most awkward applications without having to remove the hose. It can be opened and fastened again when in place without dislodging any other parts of the clamp, making assembly much easier.

The high-strength bolt designed and manufactured by Mikalor specifically for this clamp, together with the captive nut and spacer system allow you to clamp the most demanding of hose assemblies. This is the clamp of choice for professionals in the industrial hose, automotive and agricultural machinery sectors as well as in all industrial applications where an outstanding and above all reliable heavy-duty clamp is required. The Supra W2 clamp complies fully with the directive EU 20032/95/EC.

** Special dimensions can be manufactured on request.*

** The maximum application pressure can vary depending on the type of hose used and the geometry of the coupling.*

Application Ø									
mm	Part n°	r	e	a	b	Maximum values		Box Quantity (MOQ)	Outer Packing
						Torque (Nm)	Pressure (Bars)		
17-19	0301901-2	M6	8	18 ⁺⁰²	19,8	10	45	50	400
19-21	0301902-0	M6	8	18 ⁺⁰²	19,8	10	45	50	400
21-23	0301903-9	M6	8	18 ⁺⁰²	19,8	10	45	50	400
23-25	0301904-7	M6	8	18 ⁺⁰²	19,8	10	45	50	400
25-27	0301905-5	M6	8	18 ⁺⁰²	19,8	10	45	50	400
27-29	0301906-3	M6	8	18 ⁺⁰²	19,8	10	45	50	200
29-31	0301907-1	M7	10	20 ⁺⁰³	22	13	40	50	50
31-34	0301908-0	M7	10	20 ⁺⁰³	22	13	40	50	50
34-37	0301909-8	M7	10	20 ⁺⁰³	22	13	40	50	50
37-40	0301910-0	M7	10	20 ⁺⁰³	22	13	40	50	50
40-43	0301911-9	M7	10	20 ⁺⁰³	22	13	40	50	50
43-47	0301912-7	M7	10	20 ⁺⁰³	22	16	36	50	50
47-51	0301913-5	M7	10	20 ⁺⁰³	22	16	36	50	50
51-55	0301914-3	M7	10	20 ⁺⁰³	22	16	36	25	25
55-59	0301915-1	M7	10	20 ⁺⁰³	22	16	36	25	25
59-63	0301916-0	M7	10	20 ⁺⁰³	22	16	36	25	25
63-68	0301917-8	M7	10	20 ⁺⁰³	22	16	36	25	25
68-73	0301918-6	M8	13	25 ⁺⁰⁴	27,5	30	28	25	25
73-79	0301919-4	M8	13	25 ⁺⁰⁴	27,5	30	28	25	25
79-85	0301920-7	M8	13	25 ⁺⁰⁴	27,5	30	28	25	25
85-91	0301921-5	M8	13	25 ⁺⁰⁴	27,5	30	20	25	25
91-97	0301922-3	M8	13	25 ⁺⁰⁴	27,5	30	20	25	25
97-104	0301923-1	M8	13	25 ⁺⁰⁴	27,5	30	20	25	25
104-112	0301924-0	M8	13	25 ⁺⁰⁴	27,5	30	12	25	25

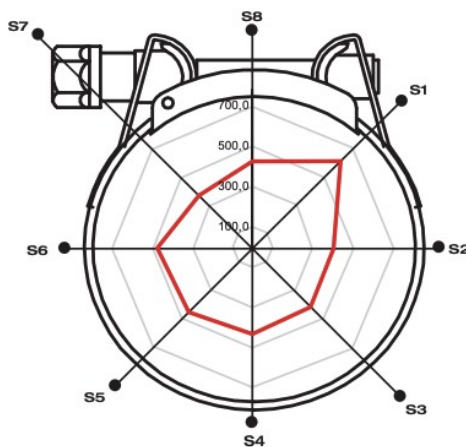

Polar Diagram

● Sectors	S1	S2	S3	S4	S5	S6	S7	S8
— 35 Nm	611,0	404,0	410,0	435,0	456,0	472,0	372,0	428,0

Torque / Efficiency [Nm / daN]

Application Ø									
mm	Part n°	r	e	a	b	Maximum values		Box Quantity (MOQ)	Outer Packing
						Torque (Nm)	Pressure (Bars)		
112-121	0301925-8	M8	13	25 ⁺⁰⁴	27,5	30	12	25	25
121-130	0301926-6	M8	13	25 ⁺⁰⁴	27,5	30	12	25	25
130-140	0301927-4	M10	15	28 ⁺⁰⁴	31	45	9	10	10
140-150	0301928-2	M10	15	28 ⁺⁰⁴	31	45	9	10	10
150-162	0301929-0	M10	15	28 ⁺⁰⁴	31	45	9	10	10
162-174	0301930-3	M10	15	28 ⁺⁰⁴	31	45	6	10	10
174-187	0301931-1	M10	15	28 ⁺⁰⁴	31	45	6	10	10
187-200	0301932-0	M10	15	28 ⁺⁰⁴	31	45	6	10	10
200-213	0301933-8	M10	15	28 ⁺⁰⁴	31	45	3	10	10
213-226	0301934-6	M10	15	28 ⁺⁰⁴	31	45	3	10	10
226-239	0301935-4	M10	15	28 ⁺⁰⁴	31	45	3	10	10
239-252	0301936-2	M10	15	28 ⁺⁰⁴	31	45	3	10	10
252-265	0301937-0	M10	15	28 ⁺⁰⁴	31	45	3	10	10
265-278	0301947-7	M10	15	28 ⁺⁰⁴	31	45	3	10	10
278-291	0301939-2	M10	15	28 ⁺⁰⁴	31	45	3	10	10
291-304	0301940-3	M10	15	28 ⁺⁰⁴	31	45	3	10	10
304-317	0301941-1	M10	15	28 ⁺⁰⁴	31	45	3	10	10
317-330	0301948-5	M10	15	28 ⁺⁰⁴	31	45	3	10	10
330-343	0301942-2	M10	15	28 ⁺⁰⁴	31	45	3	10	10
343-356	0301943-3	M10	15	28 ⁺⁰⁴	31	45	3	10	10
356-369	0301944-4	M10	15	28 ⁺⁰⁴	31	45	3	10	10
369-382	0301945-5	M10	15	28 ⁺⁰⁴	31	45	3	10	10
382-395	0301949-9	M10	15	28 ⁺⁰⁴	31	45	3	10	10
395-408	0301950-0	M10	15	28 ⁺⁰⁴	31	45	3	10	10

* It is recommended to apply 75% of the maximum values contained in the table.

TECHNICAL INFORMATION	
MATERIAL	BAND AND BRIDGE: STAINLESS STEEL X6CR17 AISI-430 SCREW: STEEL Qst 34-3(DIN 1.0213) 8.8 grade steel
FINISH	STAINLESS STEEL
CORROSION RESISTANCE	72 HOURS SALT SPRAY (ASTM B-117)
MAXIMUM TIGHTENING SPEED (RPM)	540 ±5

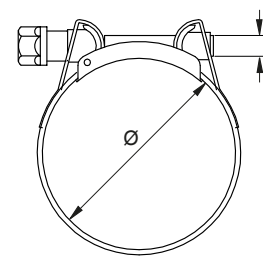
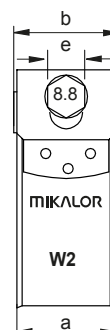
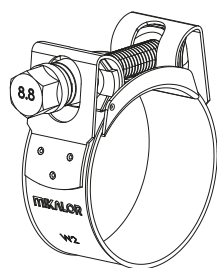



info@iq-parts.nl
Harsweg 34A
2461 EZ Ter Aar
T +31 252 624 126
The Netherlands