

iQ parts
IQ-PARTS-SHOP.COM



**SPECS &
INFORMATION**

Worm Drive Hose Clamps- SAE Type "F"

We offer multiple grades and sizes of traditional worm drive hose clamps.

H Series - "Gold Seal" Clamps

- 200/300 series stainless steel band and housing
- Heat treated carbon steel screw with 5/16" slotted hex head and plated with trivalent chromate
- Good general purpose clamp
- Ultimate Torque: 50 in.lbs. min (5.6Nm) Installation Torque: 30-40in.lbs. (3.4- 4.5Nm)

HSS Series - All Stainless Steel Clamps

- 200/300 series stainless steel band and housing
- 400 series stainless steel 5/16" slotted hex head screw
- Moderate corrosion resistance perfect for industrial installations
- Ultimate Torque: 60in.lbs. min. (6.8Nm) Installation Torque: 35-45in.lbs. (4.0-5.1Nm)

HFSS Series - All 300 Series Stainless Steel Clamps

- 300 series stainless steel band, housing and 5/16" slotted hex head screw
- All 300 series stainless steel construction provides better corrosion resistance than HSS Series
- Well suited for marine applications
- Ultimate Torque: 60in.lbs. min. (6.8Nm) Installation Torque: 35-45in.lbs. (4.0-5.1Nm)

HGSS Series - All 304 Series Stainless Steel Clamps

- 304 series stainless steel band, housing and screw
- Suitable for harsh environments and marine applications
- Ultimate Torque: 60in.lbs. min. (6.8Nm) Installation Torque: 35-45in.lbs. (4.0-5.1Nm)

HLSS Series - All 316 Series Stainless Steel Clamp

- 316 series stainless steel band, housing and screw
- Our most durable clamp for excellent performance in highly corrosive environments
- Suitable for plumbing, water well, municipal storm drains, irrigation, marine, transportation and Petrochemical applications
- Ultimate Torque: 60in.lbs. min. (6.8Nm) Installation Torque: 35-45in.lbs. (4.0-5.1Nm)

HMSS Series - All Stainless Steel Clamp With 9/16" Wide Band

- 200 series stainless steel band and housing
- 400 series stainless steel 5/16" slotted hex head screw
- 9/16" wide band
- Ultimate Torque: 60in.lbs. min. (6.8Nm) Installation Torque: 35-45in.lbs. (4.0-5.1Nm)

Clamp Series	"A" Diameter Range					
SAE Size	Decimals		Inches		Millimeters	
6	0.44	0.78	7/16	25/32	11	20
8	0.44	0.91	7/16	29/32	11	23
10	0.56	1.06	9/16	11/16	14	27
12	0.69	1.25	11/16	11/4	18	32
16	0.75	1.5	3/4	11/2	19	38
20	0.81	1.75	13/16	1 3/4	21	44
24	1.06	2	1 1/16	2	27	51
28	1.31	2.25	1 5/16	2 1/4	33	57
32	1.56	2.5	1 9/16	2 1/2	40	64
36	1.81	2.75	1 13/16	2 3/4	46	70
40	2.06	3	2 1/16	3	52	76
44	2.31	3.25	2 5/16	3 1/4	59	83
48	2.56	3.5	2 9/16	3 1/2	65	89
52	2.81	3.75	2 13/16	3 3/4	71	95
56	3.06	4	3 1/16	4	78	102
60	3.31	4.25	3 5/16	4 1/4	84	108
64	3.56	4.5	3 9/16	4 1/2	90	114
72	4.06	5	4 1/16	5	103	127
80*	4.56	5.5	4 9/16	5 1/2	116	140
88*	5.06	6	5 1/16	6	129	152
96	5.56	6.5	5 9/16	6 1/2	141	165
104	6.06	7	6 1/16	7	154	178
116	6.5	7.75	6 1/2	7 3/4	165	197
128	5.69	8.5	5 11/16	8-12	144	216

*items not stocked. special order only

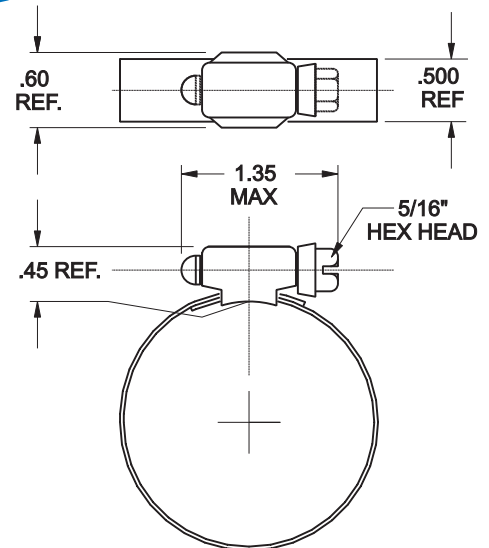

Applies to: H, H-SS, HF-SS, HL-SS Series

Part Number Explanation

Hxx

HxxSS

HFxxSS

HGxxSS

HLxxSS

HMxxSS

xx=SAE Size

Select the series and add the SAE size to determine your part number.

Then add the part number extension: 00C for Bulk, 00P for 10 PC Packers

All 304 Stainless Steel Construction Clamp

HG40SS00P

SAE Size

10 PC Packers



info@iq-parts.nl
Harsweg 34A
2461 EZ Ter Aar
T +31 252 624 126
The Netherlands