

iQ parts
IQ-PARTS-SHOP.COM



**SPECS &
INFORMATION**

TAMPER-PROOF INSTALLATION CLAMPS

For the secure and reliable fastening of all types of signage, street furniture and other mountable equipment to posts ranging from 55mm to 340mm in diameter. Manufactured from high strength stainless steel and with a hardened tamper-resistant screw featuring a unique recessed seven-sided socket.

Typical applications include the securing of road signs, advertising displays, street furniture and electronic systems such as PA systems and CCTV cameras.

VANDAL RESISTANT

Tamtorque tamper-proof clamps can only be tightened or released with a special Tamtorque screw bit, and are tough enough to withstand even the most persistent attack.

USER-FRIENDLY

Tamtorque clamps are safe, quick and easy to use and feature a patented auto locking safety buckle that ensures the free end of the band is both safe and tidy.

RE-USABLE

Tamtorque tamper resistant clamps can be used over and over again. They are easily loosened, repositioned or removed completely using the special Tamtorque tool.

STRENGTH

Using our Hi-Torque in-line housing design, Tamtorque offers unrivalled levels of strength allowing it to be used on large signage and in windy conditions. Real world tests have shown Tamtorque clamps will take in excess 1 ton of weight trying to pull them apart.



THE RANGE

Size	For post diameters *	
	mm	ins
70	55-70	2 1/8 - 2 3/4
100	70-100	2 3/4 - 4
130	100-130	4 - 5 1/8
(160)	130-160	5 1/8 - 6 1/4
190	130-190	5 1/8 - 7 1/2
250	190-250	7 1/2 - 9 7/8
340	250-340	9 7/8 - 13 3/8

* For close fitting brackets. It will be necessary to make an allowance for the extra band length that U brackets and similar require.

() = Not required for a complete range but useful intermediate size for many applications.

TECHNICAL & MATERIAL SPECIFICATION

BAND WIDTH

16mm (5/8")

MATERIAL SPECIFICATIONS

Band, Housing, Buckle:
BS304 – EN 1.4301

Screw: BS410 – EN 1.4006
heat treated to 1220N/mm²

RECOMMENDED SETTING TORQUE

10-15 Nm (90-130 lb.in)

EASY TO USE

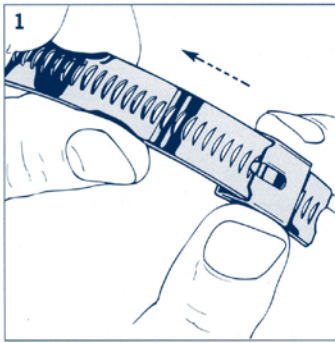

Slide the buckle onto the band in the direction of the arrow and push around to the housing.

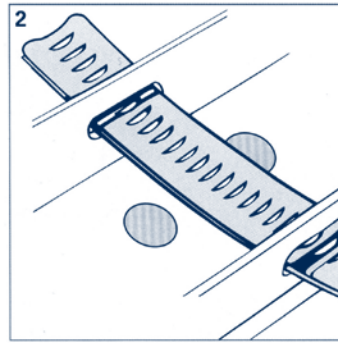

Thread the band through the slots in the sign and around post.

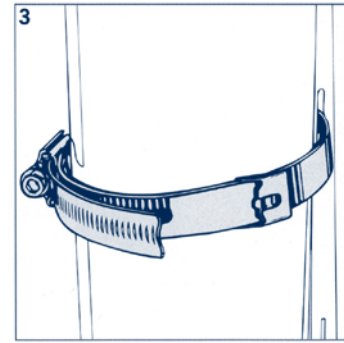

Engage the band into the screw housing and screw band through by approximately 50mm.

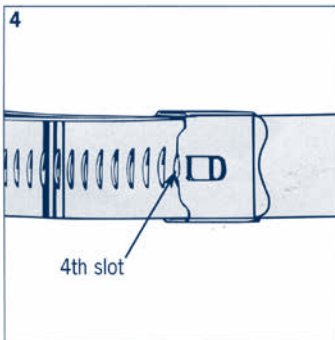

Locate the tongue of the buckle in the 4th slot of the band. Screw the band through using a hand or power tool.

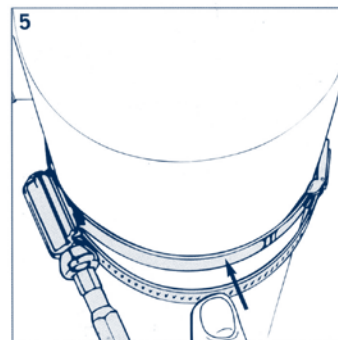

Hold down any excess band just before the buckle is clamped. Finally tighten with the ratchet spanner.

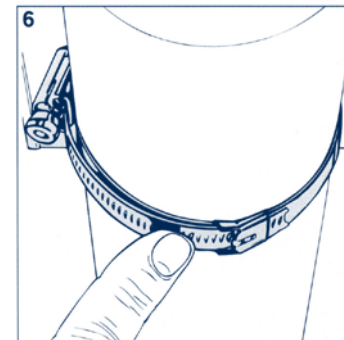

Push any remaining excess band through the buckle for a safe, tidy job. Tamtorque can be released and repositioned if required.

TAMTORQUE® TOOLS



RATCHET SPANNER

1/4" square ratchet driver complete with a tamtorque socket bit.



COMBI DRIVER

A screwdriver and T-bar combination tool with non-removable Tamtorque bit.



LONG REACH BIT

1/4" hex x 170mm long bit for direct insertion into cordless drill/drivers.



TOOL BIT

1/4" hex x 50mm long bit for direct insertion into cordless drill/driver. Two bits per bag.



SOCKET BIT

For use with the Tamtorque or other ratchet spanners.



info@iq-parts.nl
Harsweg 34A
2461 EZ Ter Aar
T +31 252 624 126
The Netherlands